



**Series IN566G Deluxe Clinical Care Recliner**

**Series IN566DG Deluxe Clinical Care Recliner with Drop Arm**

**Series IN566GH Deluxe Clinical Care Recliner  
with Heat and Massage**

**Series IN566DGH Deluxe Clinical Care Recliner with Drop Arm  
with Heat and Massage**

**Series IN566GHO Deluxe Clinical Care Recliner  
with Heat Only**

**Series IN566DGHO Deluxe Clinical Care Recliner with Drop Arm  
with Heat Only**



## **ASSEMBLY AND OPERATING INSTRUCTIONS**

**SAVE THIS MANUAL FOR FUTURE USE.**

# CONTENTS

INTRODUCTION .....	3
INTENDED USE .....	3
IMPORTANT SAFETY PRECAUTIONS—READ BEFORE USE .....	3
WARNINGS .....	3
ASSEMBLY .....	5
UNPACKING.....	5
PRODUCT DESCRIPTION.....	5
FEATURES, SERIES IN566G .....	5
FEATURES, SERIES IN566DG .....	5
UPHOLSTERED BACK ASSEMBLY, ALL MODELS.....	6
OPERATION .....	7
TENTE® CASTERS, ALL MODELS .....	7
SIDE TABLE OPERATION, ALL MODELS.....	8
TO RAISE TABLE .....	8
TO LOWER TABLE.....	8
SIDE PANEL OPERATION.....	9
SERIES IN566G .....	9
SERIES IN566DG.....	9
RECLINER OPERATION, ALL MODELS .....	10
FIRST POSITION .....	10
SECOND POSITION .....	10
THIRD POSITION.....	11
TRENDLENBURG POSITION (ALSO KNOWN AS SHOCK POSITION) .....	11
DROP ARM FUNCTION, SERIES IN566DG ONLY .....	12
TO OPERATE THE DROP ARM FEATURE .....	12
RECLINERS WITH HEAT AND MASSAGE OR HEAT ONLY FEATURE.....	13
INSTALLATION AND OPERATING GUIDE .....	13
DESCRIPTION .....	13
CONNECTION.....	13
MAIN COMPONENTS.....	13
HEAT AND MASSAGE / HEAT ONLY INSTALLATION INSTRUCTIONS .....	14
HEAT AND MASSAGE / HEAT ONLY UNIT OPERATION INSTRUCTIONS.....	16
HEAT AND MASSAGE / HEAT ONLY UNIT TROUBLESHOOTING GUIDE.....	18
CARE AND MAINTENANCE .....	19
EVERY THREE MONTHS .....	19
UPHOLSTERY MAINTENANCE AND STAIN REMOVAL .....	19
FOR GUARDIAN, PATRIOT PLUS, RENAISSANCE AND SAVOY FABRICS ONLY .....	19
COLOR TRANSFER .....	19
DISINFECTANTS .....	19
CDC RECOMMENDATIONS .....	20
DISPOSAL AND KEY TO SYMBOLS .....	22
DISPOSAL.....	22
KEY TO SYMBOLS.....	23
TECHNICAL SPECIFICATIONS.....	24
LIMITED WARRANTY .....	25
INDEX.....	27

# INTRODUCTION

This manual contains assembly, operation, and maintenance instructions for Intensa Clinical Care Recliners Series IN566G (Models IN566G, IN566GH, and IN566GHO) and IN566DG (Models IN566DG, IN566DGH, and IN566DGHO). Read the entire manual carefully before using your recliner, and refer to it during use if you have questions. If you have further questions, call Graham-Field / Intensa Technical Support at 1.770.368.4700.

## INTENDED USE

Intensa Clinical Care Recliners are intended to make the care, treatment and recovery of patients easier and more comfortable. Intensa Clinical Care Recliners are used in a wide range of healthcare applications including Dialysis, Oncology, Drug Delivery, Same Day Surgery and Post-Operative Recovery. Intensa Clinical Care Recliners are ideal for use in hospitals, clinics and rehabilitation centers.

Intensa Series IN566G / IN566DG Recliner supports patient weights up to 400 lb (181 kg), EVENLY DISTRIBUTED.

## IMPORTANT SAFETY PRECAUTIONS—READ BEFORE USE

The safety statements presented in this chapter refer to the basic safety information that the Series IN566G / IN566DG user must pay attention to and abide by. There are additional safety statements in other chapters or sections, which may be the same as or similar to the following, or specific to the operations. Please note the following special statements, used throughout this manual, and their significance:

- ⚠ WARNING:** Indicates a potential hazard situation or unsafe practice that, if not avoided, could result in death or serious personal injury.
- ⚠ CAUTION:** Indicates a potential hazard or unsafe practice that, if not avoided, could result in minor or moderate personal injury.
- ▲ NOTICE:** Indicates a potential hazard or unsafe practice that, if not avoided, could result in product or property damage.

*Info: Provides application recommendations or other useful information to ensure that you get the most from your product.*

## WARNINGS

- ⚠ WARNING:** Read this entire manual before assembly or operation.
- ⚠ WARNING:** Periodically inspect all parts and replace as needed.
- ⚠ WARNING:** Do not use near an open flame, as the chair could be a combustion source, resulting in fire, property damage, and severe physical injury.
- ⚠ WARNING:** Service and repair of the Intensa Series IN566G / IN566DG Clinical Care Recliner must be performed by a Graham-Field authorized distributor. GF Health Products, Inc. is not responsible for any consequence resulting from any unauthorized service or repair.
- ⚠ WARNING:** The electronics and actuator contain no serviceable components. If service is required, the unit must be returned to the factory for repair. **DO NOT** attempt to open the electronics or actuator or obtain local service; this will void the warranty and may result in damage to the unit. Consult your Graham-Field authorized distributor for further information.

- ⚠ WARNING: This product has a maximum weight capacity of 400 lb (181 kg), EVENLY DISTRIBUTED.**
- ⚠ WARNING: Casters must be locked at all times, except during transport.**
- ⚠ WARNING: Unauthorized modification of your recliner or the use of non-Intensa replacement parts may change the structure of the recliner and could create a hazardous condition, which may result in serious injury and will void the warranty.**
- ⚠ WARNING: This product can expose you to chemicals including Di(2-ethylhexyl)phthalate (DEHP) which is known to the State of California to cause cancer and birth defects or other reproductive harm. For more information go to [www.p65warnings.ca.gov/furniture](http://www.p65warnings.ca.gov/furniture).**
- ⚠ WARNING: GF Health Products, Inc. specifically disclaims responsibility for any bodily injury or property damage which may occur during any use which does not comply with federal, state or local laws or ordinances.**

# ASSEMBLY

## UNPACKING

1. Check for obvious damage to the carton or its contents. If damage is evident, please notify the carrier and your Graham-Field authorized distributor.
2. Remove all packaging materials from recliner base.

## PRODUCT DESCRIPTION

### Features, Series IN566G

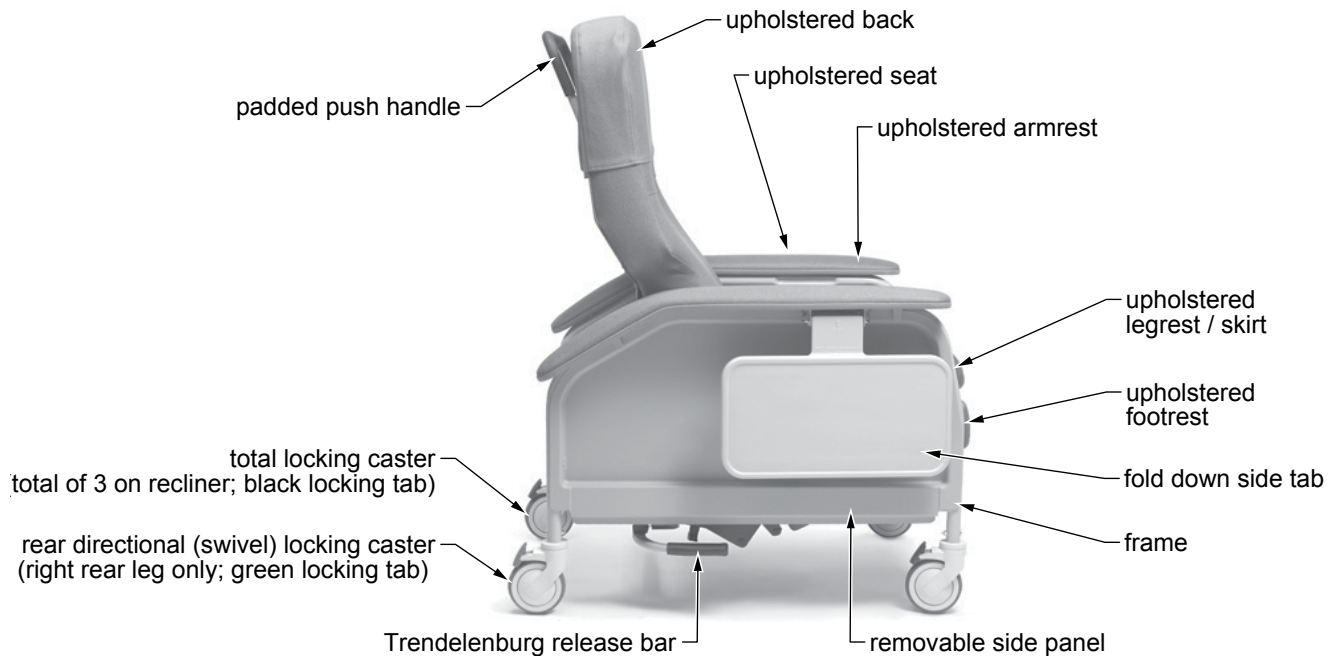

**Clinical Care Recliner Series IN566G**

### Features, Series IN566DG

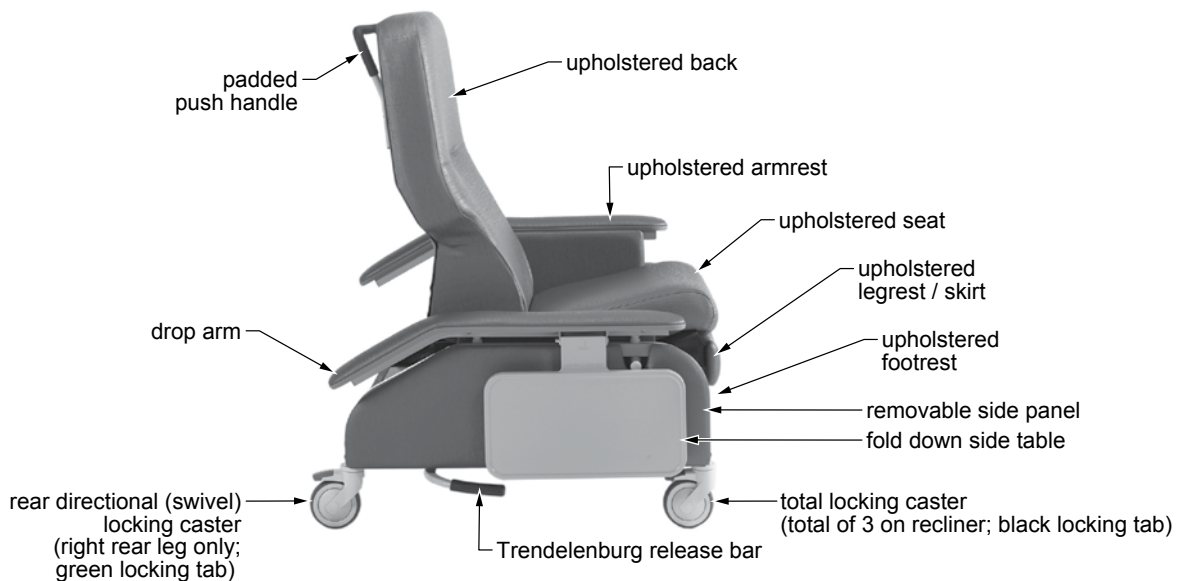

**Clinical Care Recliner Series IN566DG**

## Upholstered Back Assembly, All Models

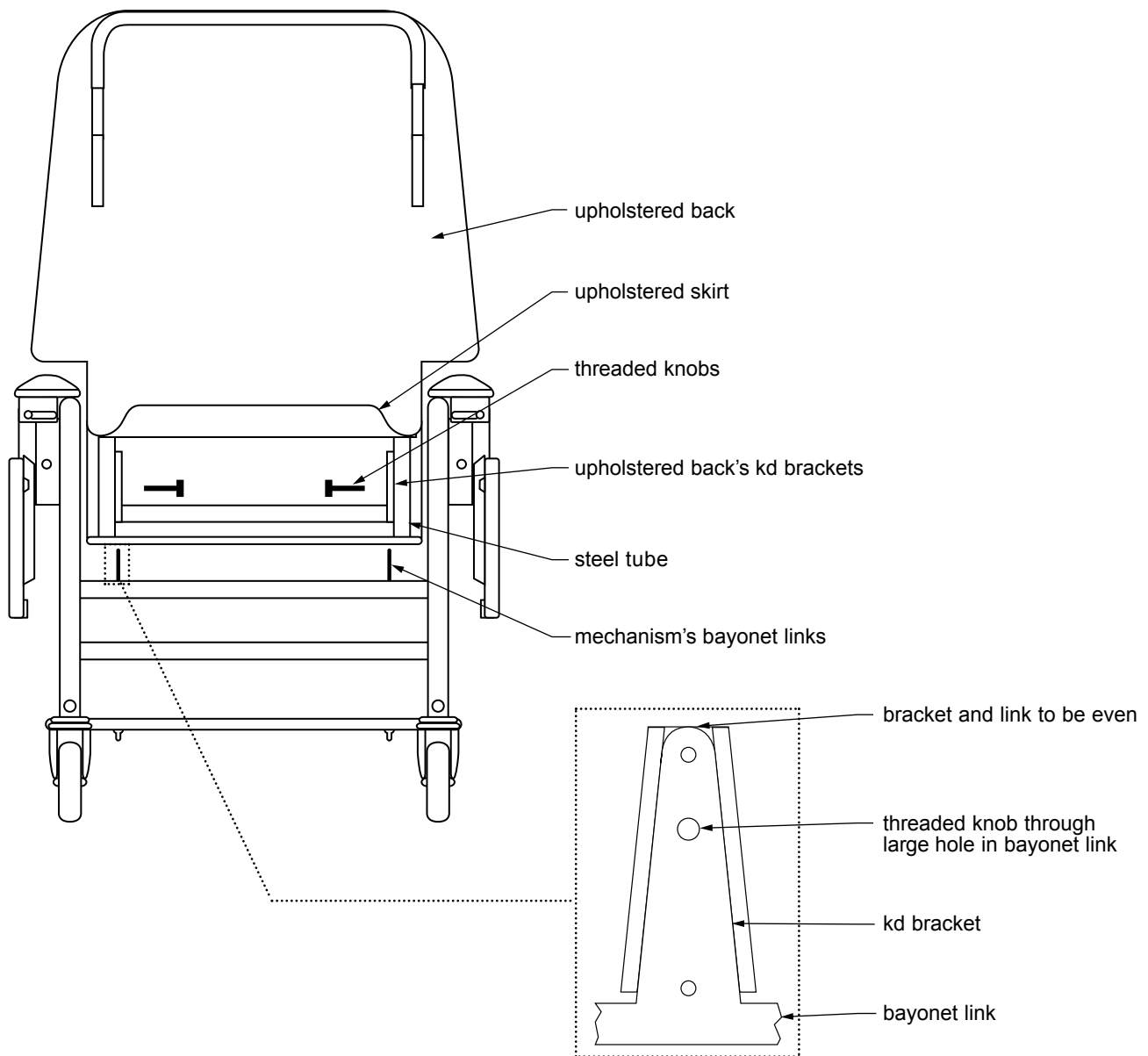

1. Lift the skirt on the rear of the upholstered back. To make assembly easier, hold skirt up with a small piece of tape to fully expose the KD (knock-down) brackets that are to be mated to the two bayonet lugs on the recliner mechanism.
2. Remove two pre-installed threaded knobs from back (one on each side).
3. Carefully guide the upholstered back onto the mechanism, inserting both bayonet links at the same time through the two cutouts located in the bottom of the back.
4. Push down firmly on the back until the recliner mechanism bayonet links are fully engaged into the upholstered back KD brackets. The top of bayonet link should be even with top of KD bracket, as shown above.
5. Once the back is properly seated onto mechanism, insert the threaded knob through bayonet link, kd bracket and steel tube (one on each side). Secure hand tight.
6. Remove tape and lower upholstery skirt. Secure back skirt with the hook and loop strips on the skirt.

## OPERATION

**⚠ WARNING: Disconnection of the device: In case of emergency, always disconnect the device by removing the power cord plug from the power outlet.**

### TENTE® CASTERS, ALL MODELS

**⚠ WARNING: Casters must be locked at all times, except during transport.**

All Intensa Clinical Care Recliners now feature the latest design, all-plastic casters from TENTE. Specifically designed for use in healthcare environments, the new casters are easier to clean, easier to move, and tolerate a wide array of cleaners and chemicals. Each caster is made from high-grade synthetic materials and features a double-ball bearing swivel head. The wheel center is made of polypropylene and the tire tread of TENTEprene (thermoplastic rubber). The gray non-marking tires feature precision ball bearings.

**Locking casters:** Each Intensa Clinical Care Recliner features three total locking casters, identified by black actuator tabs, that lock both the wheel and the swivel.

To activate the total lock, simply press down on the BLACK actuator tab until it locks. To release the total lock, press on the raised portion of the actuator tab until the lever is back in the normal operating position.

**Directional (swivel) caster:** The fourth caster, located on the right rear position of the recliner, is a directional (swivel) locking caster only. Identified by a green actuator tab, the directional lock caster will lock in one of two 180-degree positions relative to the frame (forward and backward) and allows the recliner to track straight when pushed. To activate the directional lock, simply press down on the GREEN actuator tab until it locks — you may need to move the recliner slightly until the caster locks in a straight line with the recliner frame. To release the directional lock, press on the raised portion of the actuator tab until the lever is back in the normal operating position.

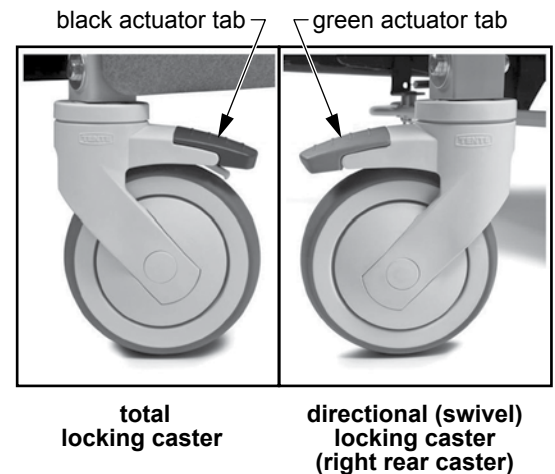

## SIDE TABLE OPERATION, ALL MODELS

### To Raise Table

Raise the side table all the way up and slide in toward the armrest until tabs engage slots in mount bracket. Press down lightly on table to ensure locking tabs are engaged.

### To Lower Table

Lift the side table up slightly until tabs disengage slots and pull table away from armrest. Lower side table to self-storing position.

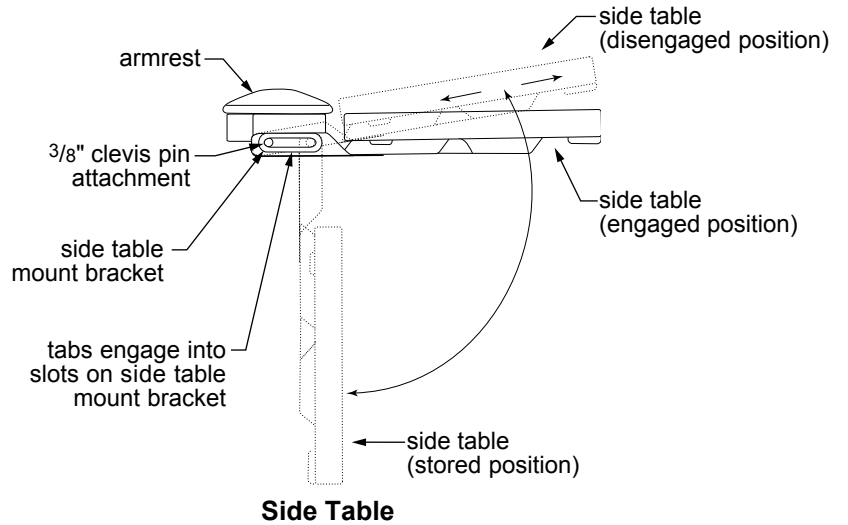



## SIDE PANEL OPERATION

For easy cleaning and access to the side and underside of the recliner, Intensa Clinical Care Recliners feature easy-to-remove side panels.

### Series IN566G

**To Remove Side Panel:** depress the two push buttons located on the lower sides of frame. Pull side panel gently away and down from frame. There are tabs on the frame underneath the armrest that hold the side panel in place.

**To Install Side Panel:** insert side panel into recliner frame by locating the tabs underneath the armrest. Make sure side panel is properly aligned and that the top edge is behind the locking tabs. Press side panel into frame sides. Make sure that both push buttons are protruding into side panel to ensure side panel is locked into place.

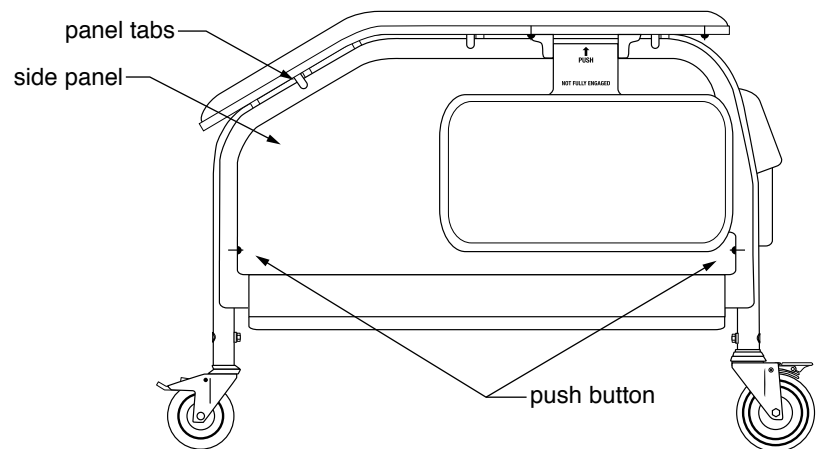

Series IN566G Removable Side Panel

### Series IN566DG

**To Remove Side Panel:** grasp upholstered side panel from both sides. Pull sharply out from recliner until locking clips release side panel from frame.

**To Install Side Panel:** insert side panel into recliner frame by lining up the side panel clips with the tubes on frame. Push side panel firmly into frame until side panel clips lock into place.

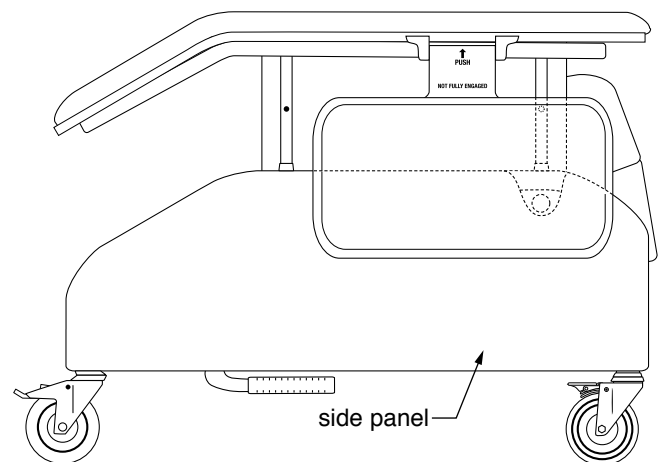

Series IN566DG Removable Side Panel

## RECLINER OPERATION, ALL MODELS

The Intensa Series IN566G / IN566DG recliners feature three positions for patient comfort. The fourth position is a Trendelenburg (or Shock) Position that must be activated by a caregiver. The Trendelenburg Position CANNOT be activated by a patient while in the recliner. In addition, this recliner features a back that can be repositioned via the Adjustment Lever located on the Push Handle on the back of the recliner.

### First Position

The first position is the Upright Position. This position is ideal for patient transport and can be used to initiate patient treatment / therapy.

### Second Position

The second position is the first recline position and is also known as TV position. This position is ideal for patient treatment, rest and reading.

#### To Achieve Second Position / First Recline Position:

- Reclining by patient: place hands on armrests and push body against recliner back to recline yourself to desired position. To bring yourself up, place hands on armrests and pull yourself up while leaning your body forward, away from the recliner back, while at the same time pushing down evenly on the footrest with your legs.
- Reclining by caregiver: standing on either side of the recliner, grasp the armrest with one hand and push handle with the other hand. Push back on push handle to recline. To return, grasp push handle and pull forward to raise the recliner back.

▲ **NOTICE: DO NOT use the footrest by itself to return the recliner to an upright position from any recline position. Doing so may damage the recliner mechanism. Please follow the instructions above to operate the recliner.**



Upright Position



First Recline Position  
(TV Position)

## Third Position

The third position is the Second Recline Position and is also known as the “Full Recline” position. This position is ideal for patient treatment, rest and reading.

### To Achieve Third Position / Second Recline Position:

- Reclining by the patient: from the First Recline Position continue to push against the back by placing your hands on the armrests and continue to recline yourself to the Second Recline Position. To bring yourself up, place hands on armrests and pull yourself up while leaning your body forward away from the recliner back while at the same time pushing down evenly on the footrest with your legs.
- Reclining by caregiver: standing on either side of the recliner, grasp the armrest with one hand and push handle with the other hand. Push back on push handle to recline. To return, grasp push handle and pull forward to raise the recliner back.



**Second Recline Position  
(Full Recline Position)**

### Trendelenburg Position (Also Known as Shock Position)

*Info: This position can only be achieved by a caregiver.*

Standing on either side of the recliner, grasp the armrest with one hand while holding the recliner back with the other. With your foot, push down on the release bar (either side of the recliner) while gently pushing down with your hand on the recliner back until it comes to a stop.

To bring recliner out of Trendelenburg, stand on either side of the recliner, grasp the armrest with one hand and push handle with the other hand and pull forward on the push handle.



**Trendelenburg Position  
(Shock Position)**

## DROP ARM FUNCTION, SERIES IN566DG ONLY

The Intensa Deluxe Clinical Care Recliner with Drop Arm (Series IN566DG) features self-storing drop arms that are simple for the caregiver to actuate. By lowering the arm, a safer and easier lateral transfer for the resident and caregiver can be achieved.

**⚠ WARNING: Always lock all recliner casters before attempting to transfer a patient. DO NOT attempt to transfer a patient if you are unsure about the physical abilities of the patient or yourself. If you are transferring a patient between two pieces of equipment, make sure both pieces of equipment are locked, are at the same height in order to reduce the amount of lifting required to transfer the patient, and are as close to one another as possible. Failure to heed these warnings could result in personal injury to the patient and / or caregiver.**

### To Operate the Drop Arm Feature

#### To Lower Drop Arm:

1. Lift fold down side table away from recliner to expose drop arm pull button.
2. Pull drop arm pull button outward while gently pushing down on the center of the armrest until arm is in the fully lowered position.

#### To Raise Drop Arm:

1. Grasp armrest with one hand and pull upward while pulling out on the drop arm pull button. Evenly raise armrest upward until drop arm pull button locks into place.
2. Ensure drop arm is secure by pushing down on center of armrest.



Series IN566DG  
Right Arm Dropped

# RECLINERS WITH HEAT AND MASSAGE OR HEAT ONLY FEATURE

HEAT AND MASSAGE: IN566GH / IN566DGH; HEAT ONLY: IN566GHO / IN566DGHO

## INSTALLATION AND OPERATING GUIDE

*Tools required: masking or packaging tape*

- ⚠ WARNING: Important! Read and understand these instructions before assembling or using the Specialty Healthcare Seating Heat and Massage / Heat Only Unit. If you do not understand any part of these warnings, cautions or instructions, contact a healthcare professional for direction in the use of this product. If the Heat and Massage / Heat Only Unit is not properly assembled, personal injury and damage to the Heat and Massage / Heat Only Unit could result.**
- ⚠ WARNING: The recliner seat and back heating elements are wired to operate in series only. Do not change the system wiring in any way.**
- ⚠ WARNING: If components are damaged or missing, contact your Graham-Field authorized distributor immediately. DO NOT use substitute parts. Use only Intensa replacement parts. The use of non-Intensa replacement parts could cause personal injury, property damage, and void the warranty.**
- ⚠ WARNING: GF Health Products, Inc. assumes no responsibility for any damage or injury caused by improper assembly or use of this product.**

### Description

The Intensa Healthcare Seating Heat and Massage / Heat Only Unit is a low-voltage (12V) Heat and Massage / Heat Only Unit, controllable by the user and / or caregiver via a handheld pendant. It is designed to enhance the comfort of the patient / resident during the use of Intensa Clinical Care Recliners. The Heat and Massage Unit offers three levels of seat and back heat, as well as a gentle or firm massage function for just the lower back or both lower and upper back; the Heat Only Unit offers three levels of seat and back heat.

### Connection

The Heat and Massage Unit comes pre-installed in Intensa Clinical Care Recliners with the Heat and Massage Option (IN566GH and IN566DGH); the Heat Only Unit comes pre-installed in Intensa Clinical Care Recliners with the Heat Only Option (IN566GHO and IN566DGHO). During recliner shipment, the Heat and Selector Switch connections are disconnected. One connection at the control box is required to make the unit functional.

### Main Components

1. All Heat and Massage / Heat Only functions are controlled by the handheld pendant.

The handheld pendant comes pre-installed and is shipped within the back compartment. To store the pendant when not in use or for caregiver use, place it in the pendant storage bracket mounted on the back of the recliner as shown at right.



Handheld Heat and Massage Pendant Shown in Storage Bracket on Back of Recliner

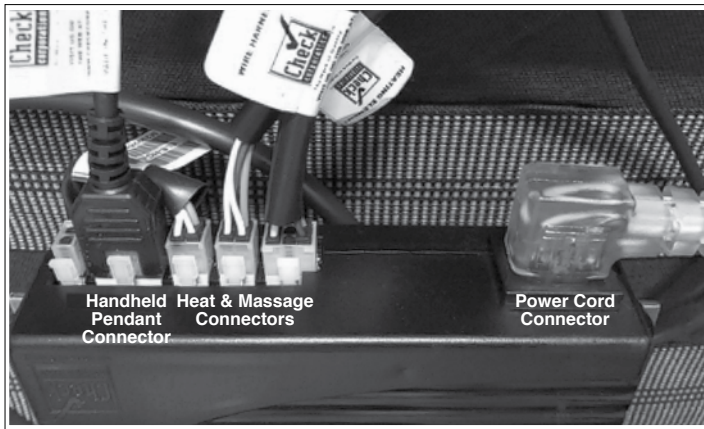

**Heat and Massage Feature —  
Control Module and Transformer Unit  
Showing All Connections Correctly Made**

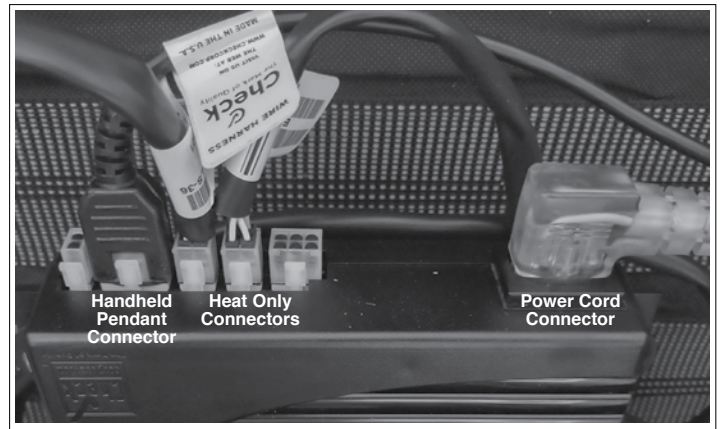

**Heat Only Feature —  
Control Module and Transformer Unit  
Showing All Connections Correctly Made**

2. The Control Module and Transformer, shown above, are contained in a single unit mounted in the back compartment. The 8-foot power cord plugs into the wall AC outlet.

### Heat and Massage / Heat Only Installation Instructions

1. Place the back cushion over the vertical bayonet lugs of the recliner mechanism. Secure the back on each side with the threaded screw knobs per the previous ***Upholstered Back Assembly*** instructions.

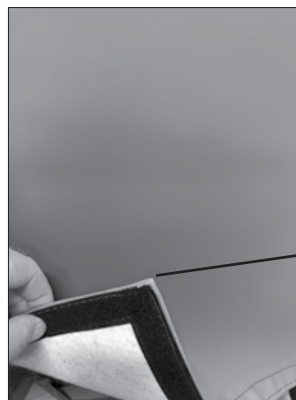

Raise Back to Access  
Back Compartment



Handheld Pendant  
Storage Bracket

Similar Model's Back  
Shown Properly  
Installed

2. Raise the back skirt on the lower rear of the back cushion, as shown at left above, and use masking or packaging tape to temporarily secure it up and out of the way. This will permit uninterrupted access to the back compartment while making the cable connection.
3. Remove the handheld pendant and power cord from the back compartment. Place the handheld pendant in the storage bracket shown at right above.

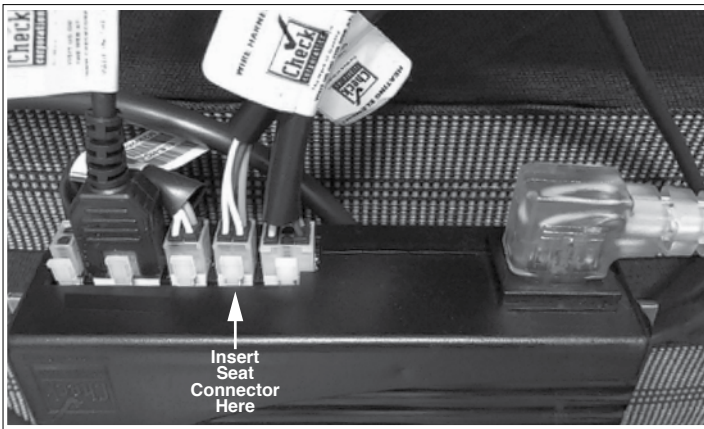

**Heat and Massage Feature —  
Install Seat Connector**

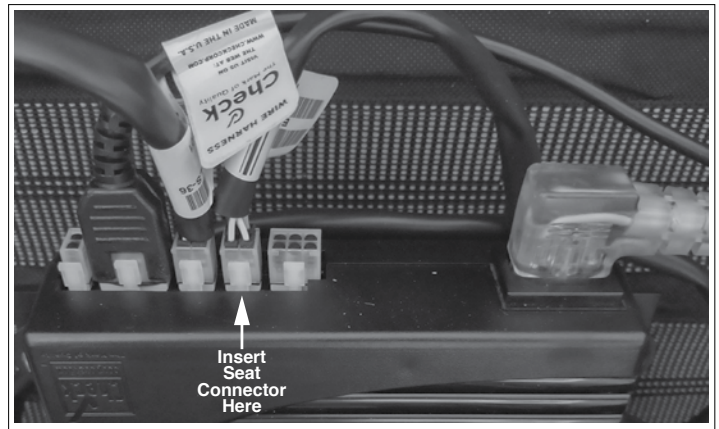

**Heat Only Feature —  
Install Seat Connector**

- There is only one connection to make — push the seat connector firmly into the control module until its locking tabs snap into place as shown above.

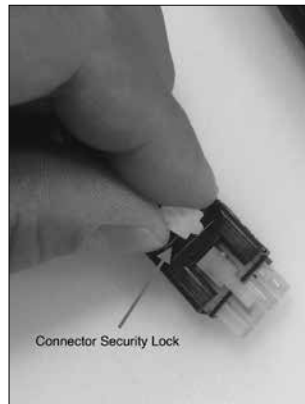

Connector Security Lock

- If you need to replace the Hand Pendant, remove the small white connector security lock as shown above.
  - Remove the tape holding the back flap. Lower the flap and seal the compartment by pressing firmly around the edges of the back flap.
  - The Heat and Massage / Heat Only Unit is now ready for operation. Instructions for use follow.
- ▲ **NOTICE: Before rolling the recliner, ensure the power cord is unplugged from the AC outlet.**

## Heat and Massage / Heat Only Unit Operation Instructions

1. Plug the power cord into any grounded outlet.



**Handheld Pendant  
Heat and Massage**



**Handheld Pendant  
Heat Only**

2. The Heat and Massage / Heat Only Unit is operated using the Handheld Pendant, shown above.



**Heat and Massage**



**Heat Only**

3. **The Heat and Massage Pendant Selector Switch Faceplate**, shown at above left, has two membrane switches. The left switch controls the Massage Function and the right switch controls the Heat Function. You can use either the Heat or Massage or both functions at the same time.

**The Heat Only Pendant Selector Switch Faceplate**, shown at above right, has a single membrane switch to control the Heat Only Function.



4. **Heat and Massage *MASSAGE* Option:** Press the *MASSAGE* switch to start this function. The Massage Function Settings are as follows:
  - a) Press selector switch for Setting 1: Gentle Lower Back Massage.
  - b) Press selector switch AGAIN for Setting 2: Firm Lower Back Massage.
  - c) Press selector switch AGAIN for Setting 3: Gentle Upper and Lower Back Massage.
  - d) Press selector switch AGAIN for Setting 4: Firm Upper and Lower Back Massage.
  - e) Press selector switch AGAIN: Massage function Shuts Off.
5. **Heat and Massage or Heat Only *HEAT* Option:** Press the *HEAT* switch to start this function. The Heat Function Settings are as follows:
  - a) Press selector switch for Setting 1: High Heat, 104°F (40°C), brightest LED.
  - b) Press selector switch AGAIN for Setting 2: Medium Heat, 101°F (38.6°C), bright LED.
  - c) Press selector switch AGAIN for Setting 3: Low Heat, 100°F (37.8°C), dim LED.
  - d) Press selector switch AGAIN: Heat function shuts off.
  - e) There is a small red indicator light, which illuminates only during the Heat function, in the selector switch. The light's brightness is determined by the Heat level being used:  
**Brightest = High Heat;                      Dimmest = Low Heat.**
6. The Unit automatically shuts off at the following times:
  - a) **HEAT FUNCTION:** After one hour of continuous use at the same level.
  - b) **MASSAGE FUNCTION:** After fifteen minutes of continuous use at the same level.
  - c) To restart the Unit, follow previous steps 4 and 5.

## Heat and Massage / Heat Only Unit Troubleshooting Guide

The cables and connections need to be validated. This will require the services of a maintenance person and a clear working area.

1. INSPECTION: Perform the following checks. If a working recliner of the same model is available, use it for comparison.

- a) Is the AC cord properly connected to the power supply? Is the cable from the power supply to the control module junction box in place?
- b) With the power supply AC cord plugged into a live AC outlet, does the small light to the left of the white seat symbol (located on the switch) light up when the switch is pressed repeatedly or is there any indication of massage operation?

**⚠ WARNING: Disconnect the power cord from the AC outlet before performing the following steps!**

- c) Is there any sign of external damage to the handheld pendant or wire?
- d) Is there any sign of external damage to the recliner?
- e) Do any of the cables show any sign of damage or pinch points?
- f) Are all cable connections to the control module in place? Are the connectors fully engaged?
- g) Are any of the connectors damaged?
- h) Are the wires within the connectors attached to the pins? Each wire may have to be tugged lightly to check if the wire is still crimped to the pin.

2. POST-INSPECTION:

- a) If improper or loose connections are found, reconnect them firmly (unless a loose wire has been found). Plug the power supply AC cord into a live wall socket and operate the unit through all functions.
- b) If the handheld pendant or wire is damaged, notify Graham-Field so that a handheld pendant can be sent for replacement.
- c) If damage to any other electrical cable or component, or disconnected wires are found, please notify Graham-Field.

3. ACTIONS:

- a) If full operation is restored, please advise Graham-Field of your successful outcome.
- b) If the fault cannot be corrected by simple re-connection, please inform Graham-Field of the results of your inspection in detail so that we may determine the appropriate action to be taken.

If you have any questions about the setup and / or operation of the Heat and Massage / Heat Only Unit, call the Graham-Field Technical Support Group at 1.770.368.4700.

## CARE AND MAINTENANCE

**⚠ WARNING: Inspect all components periodically and replace as needed.**

### EVERY THREE MONTHS

- Check and clean casters.
- Tighten bolts in each leg that secure casters into frame.
- Check caster brakes.
- Check and clean lock recline mechanism.
- Check recliner mechanism for operation in all positions, including Trendelenburg Position, with assistant seated in recliner.

### UPHOLSTERY MAINTENANCE AND STAIN REMOVAL

We recommend cleaning at least once a week to extend the lifespan of the upholstery. This prevents dirt and other contaminants from building up and stains from becoming permanent. If there is a spill, wipe off any excess right away with a dry cloth, making sure not to spread it all over the surface.

- Clean the whole surface in circular motions using liquid hand soap (pH neutral) and water (1 part soap to 9 parts water). Wipe with a clean damp cloth to get rid of any excess soap.
- Repeat as needed and then let dry.

#### **For Guardian, Patriot Plus, Renaissance and Savoy fabrics only**

If there is any build-up that can't be removed with soapy water, then use this as a last resort. Mixture: 1 part isopropyl alcohol to 1 part water.

*Info: Using alcohol on a regular basis can affect the properties of the product.*

- Once a month, you can use a soft-bristle brush for a deeper cleaning.

*Info: Light colors need more care, more often.*

*Info: The cleaning products recommended were used in a laboratory setting. Spradling Group® has no relationship with the manufacturers of those cleaning products.*

#### **Color Transfer**

Certain clothing and accessory dyes (such as those used on denim jeans) may migrate to lighter colors. This phenomenon is increased by humidity and temperature and is irreversible.

Check compatibility when using this product in combination with painted or varnished surfaces.

#### **Disinfectants**

In addition to cleaning, healthcare facilities maintain disinfecting regimens to reduce the spread of infections. There is a wide variety of available biocides that include bleaches, peroxides and quaternary ammonium products, among others. They should always be used at the recommended dilution, never in concentrated form. To prolong the life of coated fabrics, the disinfectants should be rinsed off after each use.

*Info: Misuse of disinfectants is the major source of surface deterioration. Spradling International, Inc.® continually evaluates cleaners/disinfectants, and a list of those tested can be found on their website.*

Abrasion test results exceeding ACT Performance Guidelines are not an indicator of product lifespan. Multiple factors affect fabric durability and appearance retention.

This information is not a guarantee and does not relieve the user from the responsibility of the proper and safe use of the product and all cleaning agents. The use of certain agents can be harmful to the surface appearance and lifespan of vinyl. Spradling, its agents, and assignees assume no responsibility resulting from the use of such cleaning agents to the vinyl.

Check compatibility when using this product in combination with painted or varnished surfaces.

Spradling Group® and Spradling International, Inc.® are registered trademarks of Spradling Holdings, Inc.

## **CDC RECOMMENDATIONS**

### **CLEANING AND DISINFECTING STRATEGIES FOR ENVIRONMENTAL SURFACES IN PATIENT-CARE AREAS FOR VINYL UPHOLSTERY, WALL COVERINGS AND FLOORING**

- Select EPA-registered disinfectants, if available, and use them in accordance with the manufacturer's instructions.
- Do not use high-level disinfectants / liquid chemical sterilants for disinfection of either noncritical instruments and devices or any environmental surfaces; such use is counter to label instructions for these toxic chemicals.
- Follow manufacturers' instructions for cleaning and maintaining noncritical medical equipment.
- In the absence of a manufacturer's cleaning instructions, follow certain procedures:
  - Clean noncritical medical equipment surfaces with a detergent / disinfectant.
  - Do not use alcohol to disinfect large environmental surfaces.
  - Use barrier protective coverings as appropriate for noncritical surfaces that are:
    - Touched frequently with gloved hands during the delivery of patient care.
    - Likely to become contaminated with blood or body substances.
    - Difficult to clean (e.g., computer keyboards).
- Keep housekeeping surfaces (e.g., floors, walls, tabletops) visibly clean on a regular basis and clean up spills promptly.
- Use a one-step process and an EPA-registered hospital detergent / disinfectant designed for general housekeeping purposes in patient-care areas where:
  - Uncertainty exists as to the nature of the soil on the surfaces (whether it is blood or body fluid or just normal dust or dirt).
  - Uncertainty exists regarding the presence of multi drug resistant organisms on such surfaces.
- Detergent and water are adequate for cleaning surfaces in nonpatient-care areas (e.g., administrative offices). Clean and disinfect high-touch surfaces on a more frequent schedule than minimal-touch housekeeping surfaces. Clean walls, blinds, and window curtains in patient-care areas when they are visibly dusty or soiled.
- Do not perform disinfectant fogging in patient-care areas.
- Avoid large-surface cleaning methods that produce mists or aerosols, or disperse dust in patient-care areas.

- Follow proper procedures for effective uses of mops, cloths, and solutions.
  - Prepare cleaning solutions daily or as needed, and replace with fresh solution frequently according to facility policies and procedures.
  - Change the mop head at the beginning of each day and also as required by facility policy, or after cleaning up large spills of blood or other body substances.
  - Clean mops and cloths after use and allow to dry before reuse; or use single-use, disposable mop heads and cloths.
- When performing low- or intermediate-level disinfection of environmental surfaces in nurseries and neonatal units, avoid unnecessary exposure of neonates to disinfectant residues on these surfaces by using EPA-registered germicides in accordance with manufacturers' instructions and safety advisories.

# DISPOSAL AND KEY TO SYMBOLS

## DISPOSAL

Intensa Recliner equipment and accessories can be disposed of.







We recommend disassembling and dividing the equipment and components into different waste groups such as: metal, cable, electronic, recoverable resource and plastic for recycling or combustion.





Most plastic components are provided with a plastic types code and fiber content to aid sorting of plastic parts.

Product	Metal Scrap	Cable Scrap	Electronic Scrap	Plastic Recycling or Combustion
IN566G	X	X	N/A	X
IN566DG	X	X	N/A	X
IN566GH	X	X	X	X
IN566DGH	X	X	X	X
IN566GHO	X	X	X	X
IN566DGHO	X	X	X	X

## KEY TO SYMBOLS

The following symbols are used on Intensa Recliner product labels.

	MANUFACTURER
	FRAGILE, HANDLE WITH CARE
	CE MARK
	CAUTION
	EUROPEAN AUTHORIZED REPRESENTATIVE
	UNIQUE DEVICE IDENTIFIER

	GENERAL WARNING SIGN
	KEEP DRY
	ELECTRICAL AND ELECTRONIC EQUIPMENT
	CONSULT INSTRUCTIONS FOR USE
	MEDICAL DEVICE

## TECHNICAL SPECIFICATIONS

Specification	Series IN566G	Series IN566DG
Overall Height	50" (129.5 cm)	51 1/2" (130.8 cm)
Overall Width	31" (78.7 cm)	33" (83.8 cm)
Overall Depth	43" (109.2 cm)	38" (96.5 cm)
Width Between Arms	21" (53.3 cm)	23" (58.4 cm)
Arm Height from Floor	27 1/2" (69.9 cm)	28" (71.1 cm)
Arm Height from Seat	8" (20.3 cm)	8" (20.3 cm)
Seat Height	22" (55.9 cm)	22" (55.9 cm)
Seat Width	20 1/2" (52.1 cm)	20 1/2" (52.1 cm)
Seat Depth	20" (50.8 cm)	19" (48.3 cm)
Depth Fully Reclined in Trendelenburg	75" (190.5 cm)	76" (193.0 cm)
Width with Both Side Tables in Upright Position	51" (129.5 cm)	53" (134.6 cm)
Shipping Weight	145 lb (65.8 kg)	135 lb (61.2 kg)
Maximum Weight Capacity	400 lb (181 kg), EVENLY DISTRIBUTED	400 lb (181 kg), EVENLY DISTRIBUTED

For complete technical specifications, call the Graham-Field Technical Support Group at 1.770.368.4700.



# LIMITED WARRANTY

## SCOPE OF WARRANTY

GF Health Products, Inc. (GF) warrants to the original purchaser only that it will replace or repair components, at GF's sole discretion, that are defective in material or workmanship under normal use and service. All warranties are conditioned upon the proper use of the products strictly in accordance with good commercial practice and applicable GF instructions and manuals, including proper use and maintenance. To the extent that a component is warranted by a third party, GF conveys all of its rights under that warranty to the original purchaser, to the extent permitted. This limited warranty shall only apply to defects that are reported to GF's customer service team within the applicable warranty period and which, upon examination by GF or its authorized representative, prove to be a warranty item. This limited warranty is not transferable.

The warranted components and time period are set forth below:

- Frame:..... ten years
- Heat and Massage unit: ..... two years
- Heat Only unit:..... two years
- Casters:..... one year
- Upholstery: ..... one year
- All other components:..... three years

The applicable warranty period shall commence from date of shipment to the original customer, unless there is an expiration date on the component in which case the warranty shall expire on the earlier of warranty period or the expiration date.

## OBTAINING WARRANTY SERVICE

A GF Customer Service Representative must authorize warranty service. Please contact the GF Customer Service department by calling 1.770.368.4700, sending a fax request to 1.770.368.2386 or by e-mailing a request to [cs@grahamfield.com](mailto:cs@grahamfield.com). Specific directions will be provided by the Customer Service Representative. Failure to abide by the specific directions will result in denial of the warranty claim.

## EXCLUSIONS

The warranty does not cover and GF shall not be liable for the following:

- 1) Defects, damage, or other conditions caused, in whole or in part, by misuse, abuse, negligence, alteration, accident, freight damage, tampering or failure to seek and obtain repair or replacement in a timely manner;
- 2) Products which are not installed, used, or properly cleaned and maintained as required in the official manual for the applicable product;
- 3) Products considered to be of a non-durable nature including, but not limited to: filters, fuses, gaskets, lubricants, and charts;
- 4) Accessories or parts not provided by GF;
- 5) Charges by anyone for adjustments, repairs, replacement parts, installation or other work performed upon or in connection with such products which are not expressly authorized in writing, in advance, by GF;
- 6) Any labor or shipping charges incurred in the replacement part installation or repair;
- 7) Costs and expenses of regular maintenance and cleaning; and

8) Representations and warranties made by any person or entity other than GF.

**ENTIRE WARRANTY, EXCLUSIVE REMEDY AND CONSEQUENTIAL DAMAGES DISCLAIMER**

THIS WARRANTY IS GF'S ONLY WARRANTY AND IS IN LIEU OF ALL OTHER WARRANTIES, EXPRESS OR IMPLIED. GF MAKES NO IMPLIED WARRANTIES OF ANY KIND INCLUDING ANY IMPLIED WARRANTIES OF MERCHANTABILITY OR FITNESS FOR A PARTICULAR PURPOSE. IF ANY MODEL OR SAMPLE WAS SHOWN TO THE CUSTOMER, SUCH MODEL OR SAMPLE WAS USED MERELY TO ILLUSTRATE THE GENERAL TYPE AND QUALITY OF THE PRODUCT AND NOT TO REPRESENT THAT THE PRODUCT WOULD NECESSARILY CONFORM TO THE MODEL OR SAMPLE IN ALL RESPECTS. THIS WARRANTY IS LIMITED TO THE REPAIR OR REPLACEMENT OF THE DEFECTIVE PARTS. GF SHALL NOT BE LIABLE FOR AND HEREBY DISCLAIMS ANY DIRECT, SPECIAL, INDIRECT, INCIDENTAL, EXEMPLARY OR CONSEQUENTIAL DAMAGES, INCLUDING, BUT NOT LIMITED TO: DAMAGES FOR LOSS OF PROFITS OR INCOME, LOSS OF USE, DOWNTIME, COVER, OR EMPLOYEE OR INDEPENDENT CONTRACTOR WAGES, PAYMENTS AND BENEFITS.

The warranties contained herein contain all the representations and warranties with respect to the subject matter of this document, and supersede all prior negotiations, agreements and understandings with respect thereto. The recipient of this document hereby acknowledges and represents that it has not relied on any representation, assertion, guarantee, warranty, collateral contract or other assurance, except those set out in this document.

For additional information on this product or this warranty, please contact a GF Customer Service Representative.

**NOTES:**

- 1) Additional terms and conditions may apply.
- 2) Freight claims must be notated on the appropriate shipping documents and must be made with immediacy. International, federal and state regulations govern specific requirements for freight claims. Failure to abide by those regulations may result in a denial of the freight claim. GF will assist you in filing the freight claim.
- 3) Claims for any short shipment must be made within three (3) days of the invoice date.

# INDEX

## A

Assembly 5

## C

Care and maintenance 19

Caster, directional (swivel) 7

Casters 7

Casters, locking 7

CAUTION statement, significance 3

## D

Disposal 22

Drop arm function 12

Drop arm, lower 12

Drop arm, raise 12

## F

Features 5

## H

Heat and massage / heat only 13

Heat and massage / heat only connection 13

Heat and massage / heat only, installation and operating guide 13

Heat and massage / heat only installation instructions 14

Heat and massage / heat only, main components 13

Heat and massage / Heat only operation 16

Heat and massage / heat only troubleshooting guide 18

## I

Important safety precautions 3

Info statement, significance 3

Intended Use 3

Introduction 3

## L

Limited warranty 25

## N

NOTICE statement, significance 3

## O

Operation 7

## P

Product description 5

## R

Recliner operation 10

## S

Side panel, install 9

Side panel operation 9

Side panel, remove 9

Side table, lower 8

Side table operation 8

Side table, raise 8

Symbol key, Intensa Recliner product labels 23

## T

Technical specifications 24

Trendelenburg (shock) position 11

## U

Unpacking 5

Upholstered back assembly 6

Upholstery maintenance and stain removal 19

Upholstery maintenance: CDC recommendations 20

Upholstery maintenance: disinfectants 19

Upholstery maintenance for Guardian, Patriot Plus,  
Renaissance and Savoy fabrics 19

## W

WARNINGS 3

WARNING statement, significance 3

Warranty, limited 25

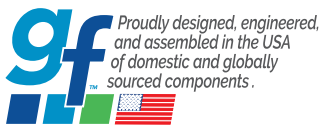

Manufactured By:  
GF Health Products, Inc. One Graham-Field Way, Atlanta, GA 30340



+1 770.368.4700

Information contained herein is subject to change without notice.  
The most current and complete product information can be found on our website.

[www.intensa.net](http://www.intensa.net) | [www.grahamfield.com](http://www.grahamfield.com)

© 2022, GF Health Products, Inc. All Rights Reserved.  
Intensa is a registered trademark of GF Health Products, Inc.

